

Reversible Compactor

MVH-R60 · 120GR/GH · 150GR/GH/D
206GH/D/DS · 306DS/DSC · 406DS/DSC · 502DSB

Features



Variable speed adjustable



Closed cover to protect battery (for electric starting type)



Self locking system



Adjustable handle height



Cyclone cleaner



Guard frame protects engine and serves as lift bar.



Combination tachometer and engine hour meter (for MVH-206GH/207GH)

MVH-306DS/DSC



Extension plate (option) increase working area by 150mm or 300mm (included with MVH-306/406/502)

Ribbed steel vibrating plate provides extra strength

Features

- Mikasa's reversible compactors range from light to heavy duty.
- Light weights models including the R60, the lightest compactor available anywhere, and the MVH-120, our best-selling compactor, are ideal for compacting trenches and finishing surfaces. (MVH-R60 through MVH-150)
- Models equipped with gasoline engines range from light to heavy duty. Choose Honda or Subaru engines. (MVH-R60 through MVH-406GH)
- Heavy duty models are ideal for compacting foundations. (MVH-206 through MVH-502)

MVH / Specifications

model	weight	dimensions	plate size	vibrating frequency	centrifugal force(max)	max. traveling speed	limited gradeability (max)	power source
MVH-R60	68kg 69kg	H: 880mm L: 886mm	W: 350mm L1: 480mm	100Hz (6,000 V.P.M)	15.0kN (1,530kgf)	25m/min	35%	Honda GX120 gasoline max.output 2.6kW(3.5PS) Subaru EX13D gasoline max.output 3.2kW(4.3PS)
MVH-120GR MVH-120GH	118kg 116kg	H: 900mm L: 1,030mm	W: 400mm L1: 585mm	100Hz (6,000 V.P.M)	22.5kN (2,300kgf)	23m/min	35%	Subaru EH17-2D gasoline max.output 3.7kW(5.0PS) Honda GX160 gasoline max.output 3.6kW(4.9PS)
MVH-150GR MVH-150GH	164kg 150kg	H: 920mm L: 1,130mm	W: 430mm L1: 700mm	90Hz (5,400 V.P.M)	27.0kN (2,750kgf)	25m/min	35%	Subaru EH25-2D gasoline max.output 5.9kW(8.0PS) Honda GX200 gasoline max.output 4.1kW(5.6PS)
MVH-150D	150kg	H: 920mm L: 1,130mm	W: 430mm L1: 700mm	90Hz (5,400 V.P.M)	27.0kN (2,750kgf)	25m/min	35%	Subaru DY23-2D diesel max.output 3.7kW(5.0PS)
MVH-206GH	208kg	H: 1,100mm L: 1,380mm	W: 500mm L1: 720mm	87Hz (5,200 V.P.M)	35kN (3,570kgf)	23m/min	35%	Honda GX240 gasoline max.output 5.3kW(7.2PS)
MVH-206D(S)	224kg (238kg)	H: 1,100mm L: 1,380mm	W: 500mm L1: 720mm	87Hz (5,200 V.P.M)	35kN (3,570kgf)	23m/min	35%	Yanmar L70N diesel (electric start) max. output 4.9kW(6.7PS)

Weight includes weight of machine, lubricants, 50% of fuel and 50% of water in case with water tank option. Features and specifications are subject to change without notification.



MVH-R60



MVH-120GR/GH



MVH-150GR/GH/D



DS type
(electric start)

MVH-206GH/D/DS/DSC



MVH-406DS/DSC



MVH-502DSB

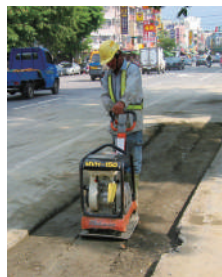
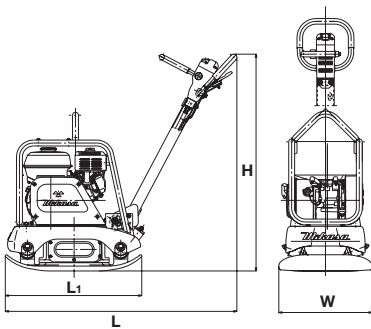

Option

Extension Plate

	width (mm)	weight (1set:kg)	set
for MVH-306,	75	17	1 set (2pcs)
406,502	150	23	



MVH-R60 Water tank (8.5 ℓ)

MVH / Specifications

model	weight	dimensions	plate size	vibrating frequency	centrifugal force(max)	max. traveling speed	limited gradeability (max)	power source
MVH-306DS/DSC	330kg	H: 970mm L: 1,570mm	W: 445mm (595mm) (745mm) L1: 860mm	73Hz (4,400 V.P.M)	45.0kN (4,600kgf)	23m/min	35%	Yanmar L70N diesel (electric start) max. output 4.9kW(6.7PS)
MVH-406DS/DSC	410kg	H: 930mm L: 1,610mm	W: 500mm (650mm) (800mm) L1: 900mm	73Hz (4,400 V.P.M)	50.0kN (5,100kgf)	23m/min	35%	Yanmar L100N diesel (electric start) max. output 7.4kW(10.0PS)
MVH-502DSB	550kg	H: 950mm L: 1,680mm	W: 550mm (700mm) (850mm) L1: 900mm	67Hz (4,000 V.P.M)	61.7kN (6,300kgf)	23m/min	35%	Hatz 1D81S diesel (electric start) max. output 9.7kW(13.2PS)

Weight includes weight of machine, lubricants, 50% of fuel and 50% of water in case with water tank option. Features and specifications are subject to change without notification.